

Wiring

Having correctly identified the wiring from your existing light fitting, pull the mains wire and connect to the terminal block (not supplied) in the following way:

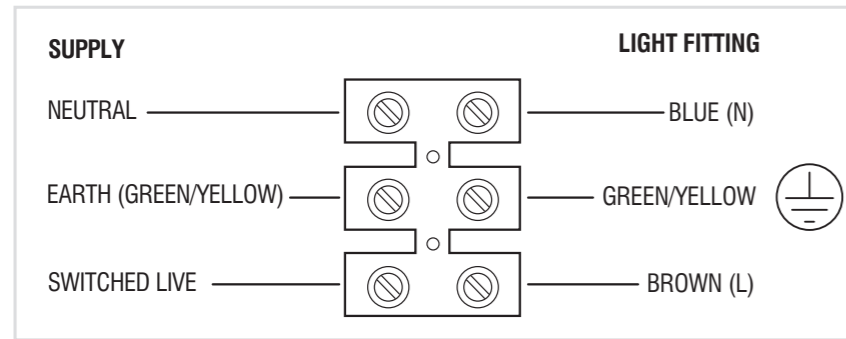

Check that...

You have correctly identified the wires
The connections are tight
No loose strands have been left out of the connection block.

Technical data

Supply Voltage: 220-240V~, 50 Hz

Bulb Type:	106733--100W LED, 4000K	This product contains a light source of energy efficiency class D .
	106734--150W LED, 4000K	This product contains a light source of energy efficiency class D .
	106735--200W LED, 4000K	This product contains a light source of energy efficiency class D .
	106736--100W LED, 4000K	This product contains a light source of energy efficiency class B .
	106737--150W LED, 4000K	This product contains a light source of energy efficiency class B .

 Non-replaceable light source |  Non-replaceable control gear



Conformity with all relevant UKCA Directive requirements.



Conformity with all relevant EC Directive requirements.



This product is Class 1, must be connected to earth.



Waste electrical products should not be disposed of with household waste. Please recycle where facilities exist. Check with your Local Authority or local store for recycling advice.



Caution! Risk of electric shock!



This product is rated at IP65.



This product is rated at IK10.

Care and Safety

We recommend cleaning with a soft dry cloth. Do not use solvents or abrasive cleaners as these could damage the finish.
For your safety, always switch off the power supply before cleaning.

Instruction manual

Helios

106733, 106734, 106735, 106736, 106737

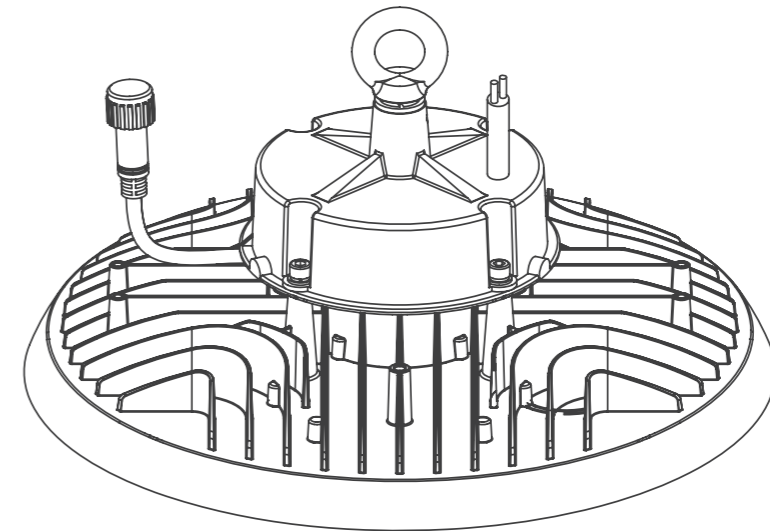

Thank you for purchasing this light fitting. Please read the instructions carefully before use to ensure safe and satisfactory operation of this product. Please retain these instructions for future reference.

Warning

This is a Class 1 product and must be earthed.

Please read these instructions carefully before commencing any work.

This unit must be fitted by a competent and qualified electrician.

Install in accordance with the IEE Wiring regulations and current Building Regulations.

Check the pack and make sure you have all the parts listed.

To prevent electrocution switch off at mains supply before installing or maintaining this fitting. Ensure other persons cannot restore the electrical supply without your knowledge. If you are in any doubt, please consult a qualified electrician.

This light fitting should be connected to a fused circuit.

If replacing an existing fitting, make a careful note of the connections.

This system contains non-replaceable parts and cannot be serviced. If damage occurs the part should be scrapped.

Waste electrical products should not be disposed of with household waste. Please recycle where facilities exist. Check with your local authority or retailer for recycling advice.

Layout

Plan the desired layout of these fittings carefully, ensuring the cables will reach the distances between each light fitting.

Avoid locating any cables in positions that would cause a hazard. Position cables and junction boxes (not supplied) away from areas where they may be at risk from being cut, trapped or damaged.

Take care not to drill into any pipes or mains cables beneath the surface during mounting holes preparation.

The mains supply cable must have a minimum cross section area of 1.0mm².

Cables must be protected using suitable conduit or plastic trunking.

Luminaires are only suitable for mounting on non-combustible surfaces.

Never put anything on the product or hang anything on any part of this product.

Accessories

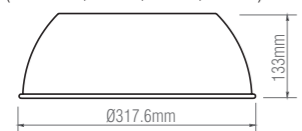
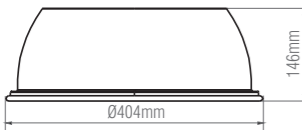
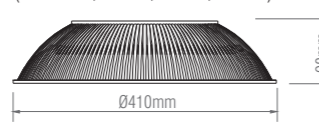
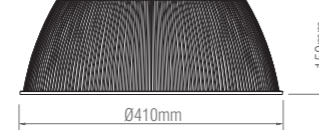
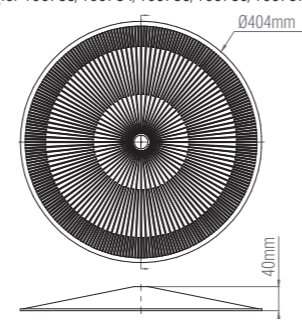
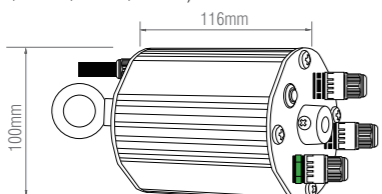
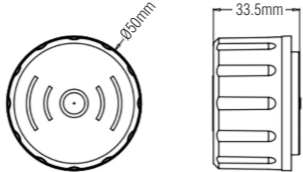
HELIOS ALUMINIUM SHADE	HELIOS POLYCARBONATE SHADE	HELIOS POLYCARBONATE SHADE BOTTOM COVER
<p>106738 (for 106733/106734/106736/106737)</p>  <p>133mm Ø317.6mm</p> <p>106739 (for 106735)</p>  <p>146mm Ø404mm</p>	<p>106740 (for 106733/106734/106736/106737)</p>  <p>98mm Ø410mm</p> <p>106742 (for 106735)</p>  <p>150mm Ø410mm</p>	<p>106743 (for 106733/106734/106735/106736/106737)</p>  <p>Ø404mm 40mm</p>
<p>HELIOS EM KIT 106744 (for 106733/106734/106735/106736/106737)</p>  <p>116mm 100mm</p>	<p>HELIOS MICROWAVE SENSOR 106745 (for 106733/106734/106735/106736/106737)</p>  <p>Ø50mm 33.5mm</p>	

Installation

Existing fittings must be completely removed before installation of a new product. Before removing the existing fitting, carefully note the position of each set of wires.

- Note that the power needs to be isolated/switched off at the fuse board.
- The fixing point(s) selected must be capable of supporting the full weight of the light fitting.

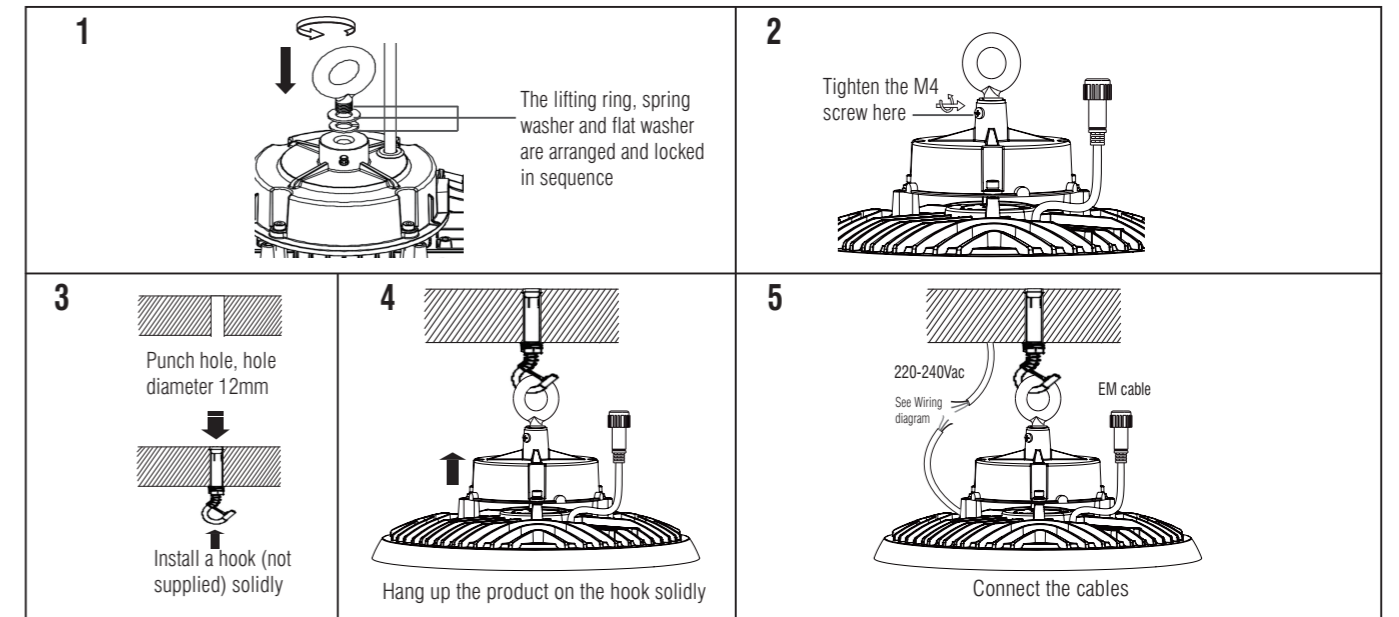

Sensor Installation

This lamp can be used with sensor (model no: 106745)
For more details please see "Microwave sensor user's manual"

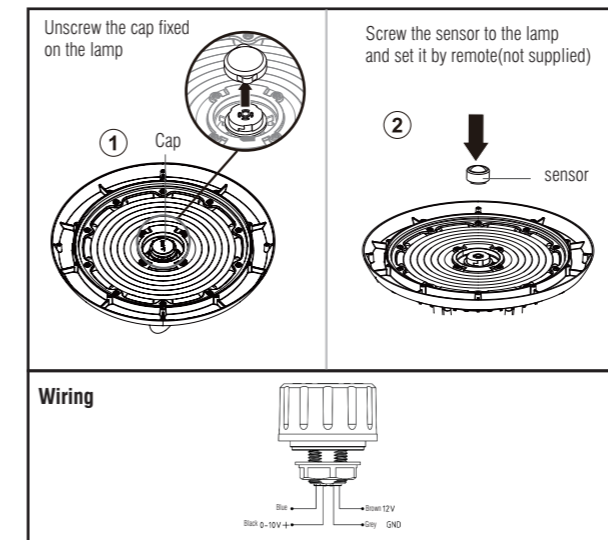

EM Kit Installation

This lamp can be used with EM kit (model no: 106744)
For more details please see "EM kit user's manual"

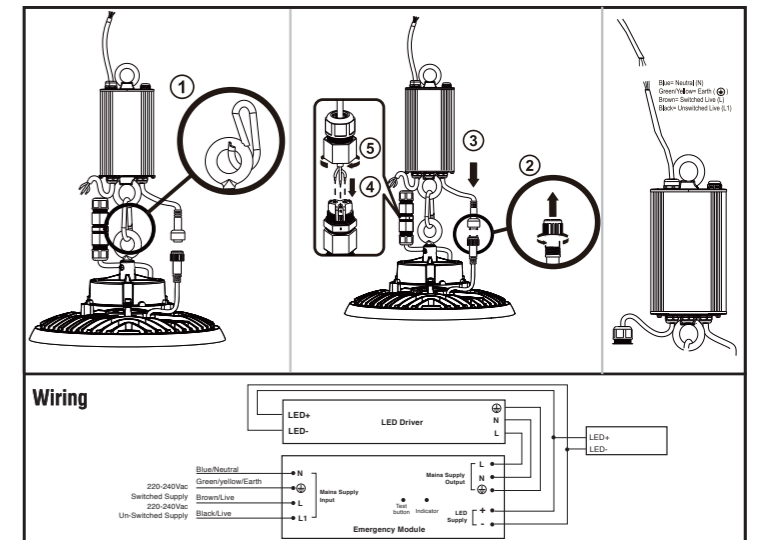

Shade Installation

