

## 5. Wiring.

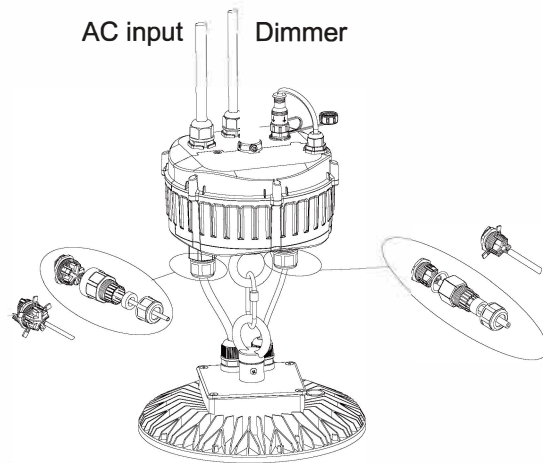

6

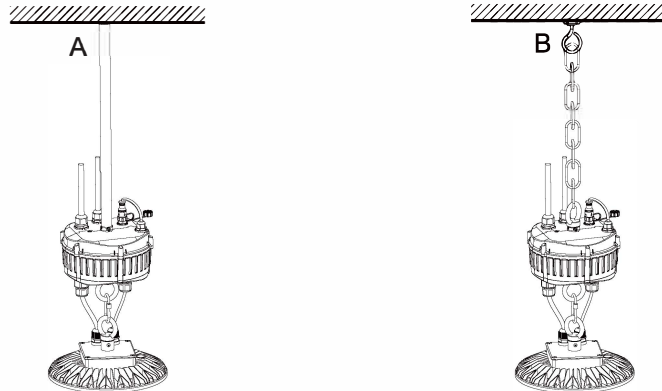

## 7. Explanation of LED indicator

State	Color	LED indication	Status	Comment
	Green	Permanent green	Charging Mode Fully Charged	AC mode
	Green	Fast flashing green (0.1 sec on, 0.1 sec off)	Function test underway	
	Green	Slow flashing green (1 sec on, 1 sec off)	Duration test underway	
	Red	Permanent red	Load failure	Open circuit/ Short circuit Led failure (emergency mode)
	Red	Slow flashing red (1 sec on, 1 sec off)	Battery failure	Battery failed the duration test or function test / No battery
		Green and red off	DC mode	Battery operation (emergency mode)



Instruction manual

# AltumPro EM Kit

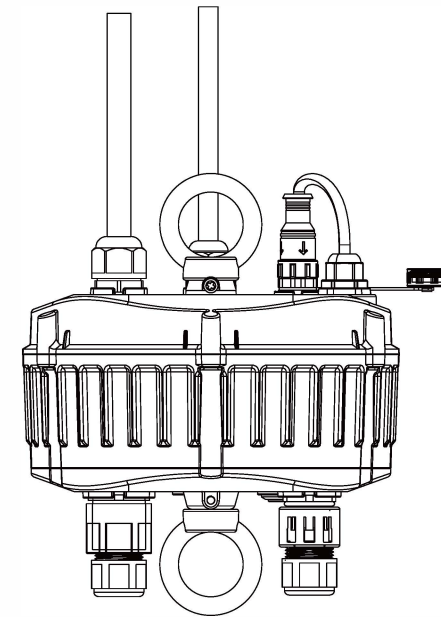
111669



Thank you for purchasing this product. Please read the instruction carefully before use to ensure safe and satisfactory operation of this product. Please retain these instruction for future reference.

-  1. Installation and commissioning may only be carried out by authorized specialists and wired in accordance with the latest IEE electrical regulations or the national standards.
-  2. Mains power must be switched off before carrying out installation.
3. The manufacturer, shall not be liable for any damage resulting from inappropriate modifications to the luminaire or faulty installation.
4. Caution, risk of electric shock.
- The control gear provides basic insulation between the LV supply and the control circuit.

Rated	Battery	Emergency power	Duration
Input: 220-240V~, 50-60Hz, 120mA, 8W, P.F>0.5 Output: DC200-250V Over voltage protection Output current: 40-120mA Surge: 2KV(L-N) 4KV(L/N-PE) Recharging current: 500mA Battery charge time: 24hours Discharging current: 0.8-2.4A Time to light: <0.5s Switch voltage: 155-175V Battery cutoff voltage: 10.6V Battery warranty: 5 years (Based on working temperature 0 - 45°)	LiFePO4 12.8V 6.3Ah (32700*6.3Ah*4pcs)	20W cp	180 minutes

Unit: mm

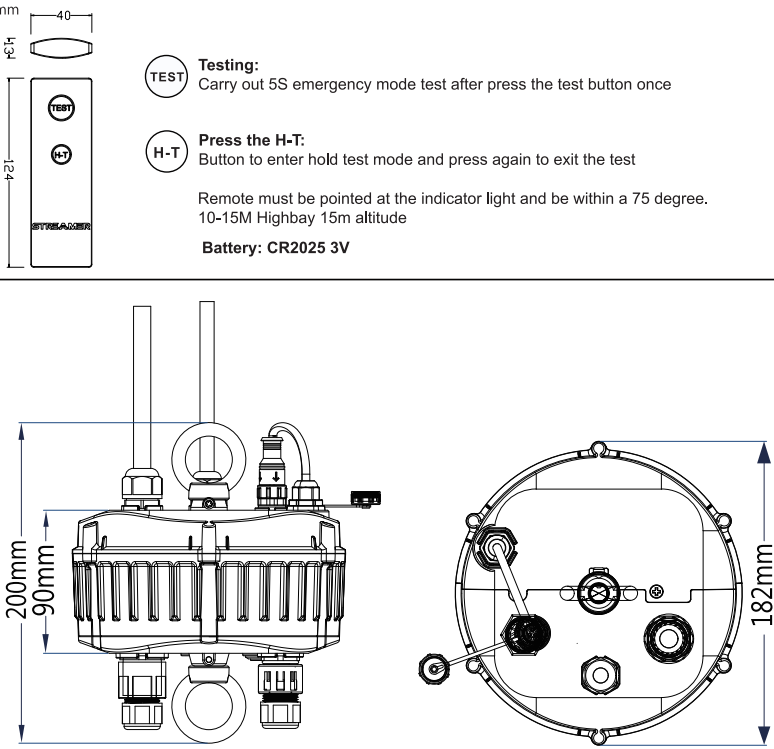

**TEST** Testing:  
Carry out 5S emergency mode test after press the test button once

**H-T** Press the H-T:  
Button to enter hold test mode and press again to exit the test

Remote must be pointed at the indicator light and be within a 75 degree.  
10-15M Highbay 15m altitude

**Battery: CR2025 3V**

1. Connect emergency driver between boom/chain and luminaire.

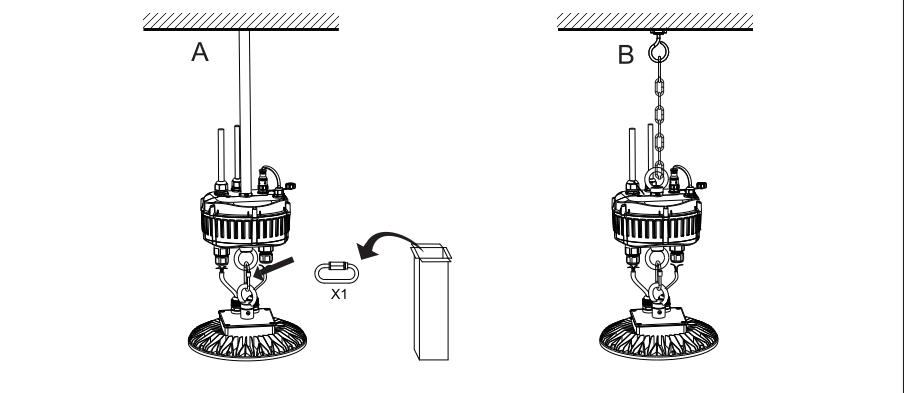

2. Connect battery.

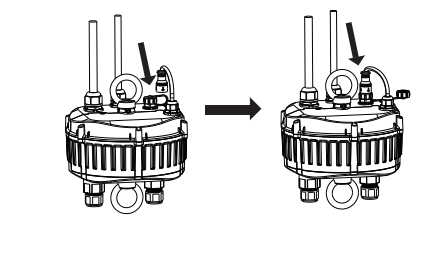

3. Remove end cap of quick connector.

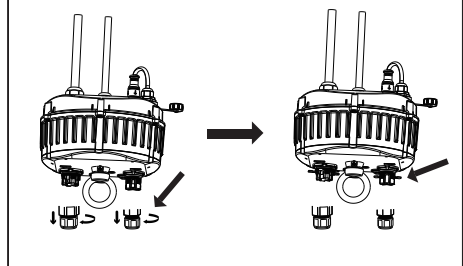

4. Check wiring diagram and power off before wiring.

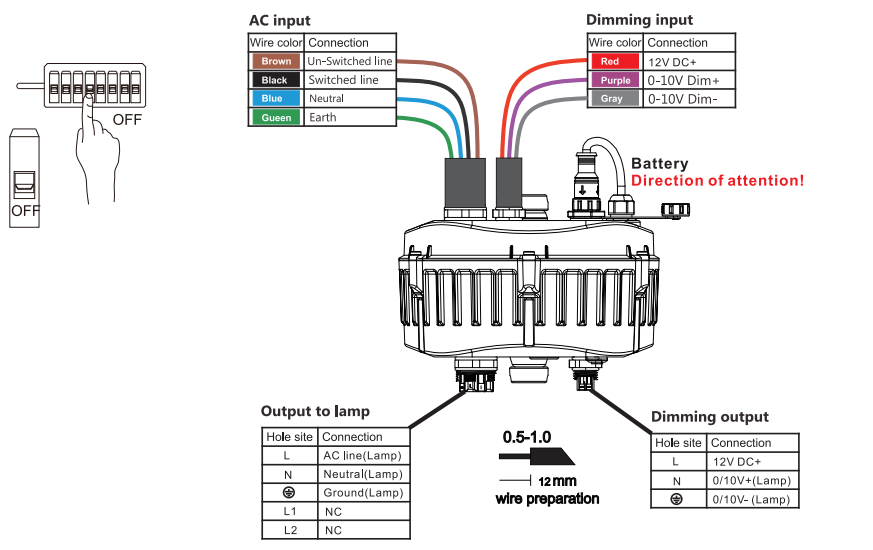

**AC input**

Wire color	Connection
Brown	Un-Switched line
Black	Switched line
Blue	Neutral
Green	Earth

**Dimming input**

Wire color	Connection
Red	12V DC+
Purple	0-10V Dim+
Gray	0-10V Dim-

**Output to lamp**

Hole site	Connection
L	AC line(Lamp)
N	Neutral(Lamp)
⊕	Ground(Lamp)
L1	NC
L2	NC

**Dimming output**

Hole site	Connection
L	12V DC+
N	0/10V+(Lamp)
⊕	0/10V-(Lamp)

**0.5-1.0**  
12mm wire preparation

**Battery**  
Direction of attention!