

INTRODUCTION

The Lantern Light incorporates a PIR (Passive Infra Red) sensing device which continuously scans a preset operating zone and immediately switches the light on when it detects movement in that area. This means that whenever movement is detected within the range of the sensor the light will switch on automatically to illuminate pathways, steps, patios, porches, or whatever area you have selected to light for reasons of safety, convenience or security.

While there is movement within range of the unit the light will remain on.

WHILE TO FIT YOUR SECURITY LIGHT

To achieve best results, we suggest you take into account the following points:

Ideally the Lantern Light should be mounted 1.8 to 2.5 meters (6 to 8ft) above the area to be scanned (refer Fig.1A).

To avoid damage to unit-do not aim the sensor towards the sun.

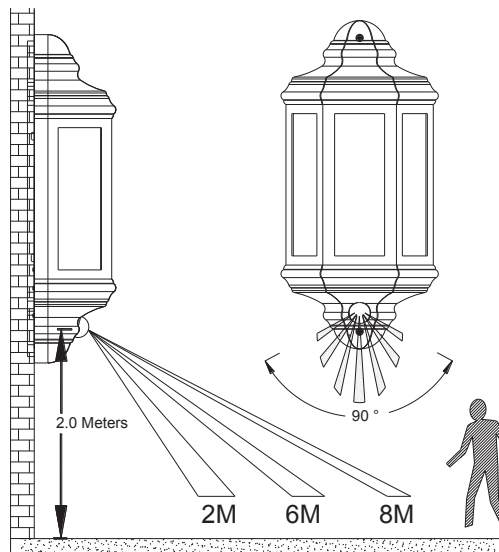

Fig.1(A) Detection Range

To avoid nuisance triggering, the sensor should be directed away from heat sources such as barbecues, Air-conditioners, other outside lighting, moving cars and flue vents.

To avoid nuisance triggering, keeping away from the area of strong electromagnetic disturbance.

Do not aim towards reflective surfaces such as smooth white walls, swimming pools, etc...

The Lantern light scanning specifications (approximately 8 meters at 90°-- round) may vary slightly depending on the mounting height and location. The detection range of the unit may also alter with temperature change. Before selecting a place to install your lantern light you should note that movement across the scan area is more effective than movement directly toward or away from the sensor (refer Fig.1B). If movement is made walking directly towards or away from the sensor and not across, the apparent detection range will be substantially reduced. (refer to Fig. 1C)

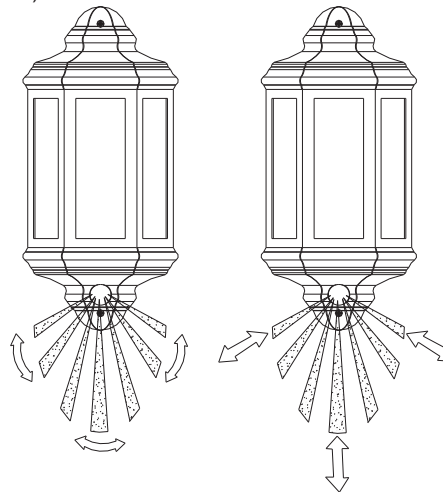

Fig.1(B) OK

Fig.1(C) NOT GOOD

FITTING THE UNIT

Before commencing any electrical work, ensure mains supply cables are isolated by switching off and removing the relevant fuse.

1. Installation by a licensed electrician and according to IEC wiring Regulation.
2. Switch power off at the meter box and ensure that there is no power to the light.
3. **IMPORTANT: DO NOT INVERT THE LANTERN.**

4. Un-screw the Screw A and Screw B as the Fig.2(A)
5. Remove the Front Cover (with Glass), please note: Open the Front Cover from the position of Screw A (showed as Fig.2 (A)), otherwise, there may be Damage to the PIR Lens.
6. Use the Mounting Base to mark the position of Fixing Wall Screw holes onto mounting surface. Then drill the wall to depth of about 4 cm with a no.8 size bit.
7. Pierce the Wiring Rubber and bring Power Cable through.
8. Fit the Mounting Base onto the mounting wall with Fixing Wall Screws and Plastic Rawl-plugs (not supplied).
9. Connect Power Cable to the Terminal Block as relative symbol, see the Fig.2(B).
10. Fit Max. 42W incandescent bulb (E27)
11. Re-fit the Front Cover onto the Body again, and please reverse the order of 5. mentioned above. See the Fig.2(A)

TECHNICAL DETAILS :

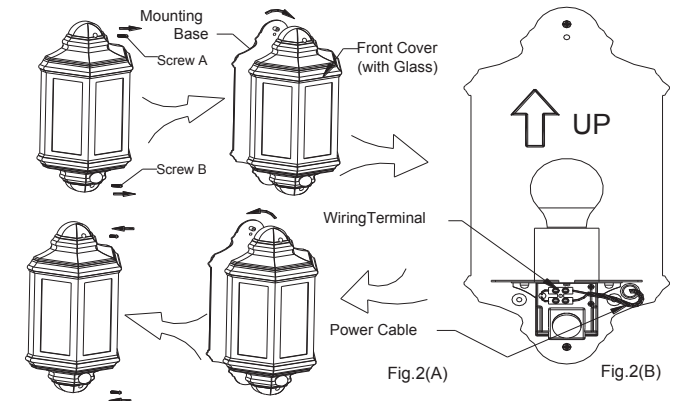

Voltage : 220-240 V~ 50 Hz

Wattage : Max. 42 Watt E27 incandescent lamp

Detection range : 90° (round) and Max. 8 meters

Duration time : about 4 minute

Weatherproof : IP44

Detection circuitry: Passive Infra-Red

Helpline

If you receive this item with parts broken or missing, please telephone: 0333 005 0077

Please have ready your name, address, tel. no., product reference, where purchased and parts required. An answering service is in operation outside office hours and during busy periods.

We regret that we are unable to give advice on internal house wiring.
Cascade Holdings Ltd,
Gorse Mill, Gorse Street, Chadderton, Oldham. OL9 9RJ